

QuadView XL Window System

Quick Start Guide For use with Windows XP

INTRODUCTION

This guide is intended to assist in quickly getting your QuadView XL into operation. It provides basic information about installing and configuring the device.

The QuadView XL can be controlled from a terminal, using a command line interface from either the RS-232 serial port, or the Ethernet network port. Alternatively you can use the Web Control Panel (WCP), a graphical interface using the internal QuadView XL web server. Each of these three methods are described separately in this *Quick Start Guide*.

1. INSTALLATION

Use the numbered steps shown in **Figure 1** to connect up your QuadView XL..

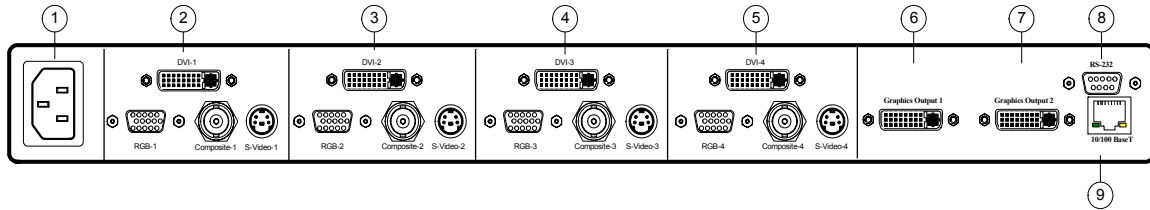

Figure 1. QV XL Rear Panel

1	AC Power Input	6	DVI / Analog RGB Output 1
2	Window 1 Inputs	7	DVI / Analog RGB Output 2
3	Window 2 Inputs	8	RS-232 Serial Control port
4	Window 3 Inputs	9	Ethernet Network control port
5	Window 4 Inputs		

Each of the window input channels is identical and consists of the following:

- Analog High Resolution RGB input
- Composite Video input
- S-Video input
- Optional DVI input

The QuadView XL is now ready for initial set up. This can be accomplished using the serial port, or the Ethernet port.. Proceed directly to the section that describes the control method you wish to use.

CONTROL CONNECTIONS

QuadView XL control can be accomplished using either the RS-232 serial port (Figure 1 – 8) or the Ethernet network port (Figure 1-9).

The serial port uses a standard DB9 female connector.

The Ethernet connector is a standard RJ45.

INPUT CONNECTIONS

Each window has an independent set of inputs as shown in **Figure 2** below. All input signals can be connected simultaneously and can be selected for display in the associated window by using the INSRC command.

NOTE: The DVI input channel is optional.

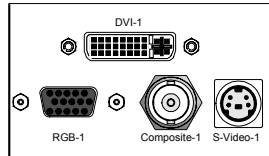

Figure 2. QV XL Input connector section (all windows)

OUTPUT CONNECTIONS

The output connectors are type DVI-I which provide both analog and digital output signals. A DVI-HD15 adapter is provided with QuadView XL as a standard item enabling you to use a standard VGA cable for use with analog display devices.

2. OPERATING QUADVIEW XL FROM THE SERIAL PORT

The QuadView XL can be controlled from an RS-232 serial control port of a terminal, terminal emulator or 3rd party serial controller. This section describes control of the QuadView XL using a terminal or PC. To use communications terminal emulators such as HyperTerminal or Procomm from your PC use the following procedure.

- Connect a serial interface cable from your PC to the QuadView XL serial port on the rear of the unit.
- Launch your serial terminal program
- In the set up section of your terminal program set the communications parameters as follows:
 - Baud Rate = 9600 baud
 - Number of data bits = 8
 - Number of start bits = 1
 - Number of stop bits = 1
 - Parity = None
 - Number of stop bits = None
- Use the terminal connect function to commence communication with the QuadView XL
- Press the enter key
- Type the command 'help'

If you have correctly connected to the QuadView XL it will respond with a list of the QuadView XL ASCII commands.

Note: The QuadView XL can be operated at baud rates up to 115 kbaud. See the QuadView XL User Guide for information on changing the baud rate.

3. OPERATING QUADVIEW XL FROM THE ETHERNET PORT

ETHERNET CONTROL METHODS

To control the QuadView XL from a computer or controller it is necessary to use the command line interface which is available from both the serial and Ethernet ports. The Ethernet port provides more flexibility as it can be used in both a point to point connection (similar to a serial connection) as well as a network environment.

When you wish to operate the QuadView XL manually, this may be conveniently accomplished using the Web Control Panel (WCP). The WCP works with your standard web browser through the Ethernet port in either the direct connection and network connection configurations.

Support for both of these approaches is provided as standard with PCs using Microsoft Windows operating systems.

DIRECT CONNECTION

In an office environment, Ethernet enabled devices are typically connected to a local area network. You can however connect between two Ethernet devices directly without a network. For example you may wish to set up a connection between a laptop computer and your QuadView XL. The set up required for these two different environments is a little different. Use the following procedure if you are intending to connect directly from your PC to the QuadView XL: If you are intending to connect to the QuadView XL over a network connection, skip this section and go to the following section.

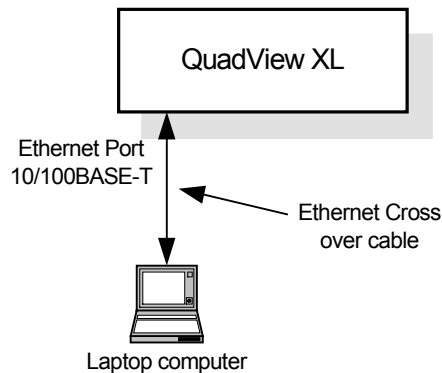

Figure 3. Direct Ethernet connection

There are several steps required to connect directly from your PC to the QuadView XL.

1. Connect Ethernet Cable

- Connect an Ethernet cross over cable between the PC Ethernet port and the QuadView XL Ethernet port.
(An example of a commercially available cable is the Belkin Part # A3X126-07-YLW-M)

Note: The standard Ethernet cable used in a network connection should **not** be used.

2. Set up the network settings of your PC (Windows XP)

Both your PC and the QuadView XL must have a unique IP address. The QuadView XL is configured with a temporary IP address (192.168.1.200) at the factory. To check that you have a valid IP address on your PC use the following procedure:

- Click on the START button of your PC and select 'RUN'
- Type 'command' in the RUN entry box
- Type 'ipconfig' at the command prompt and make a note of the list of IP settings. (if you see the message – “command not found” or similar it means that your TCP/IP utilities are not included in your Path setting. See the trouble shooting section later in this document)
- Click on the START button of your PC and select Settings ► Network Connections ► Local Area Connection
- Click on the Properties button
- Click on the “Internet Protocol (TCP/IP)” entry in the Connections dialog box
- Click on the Properties button
- Click on the “Use the following IP address” button
- Type the address 192.168.1.190 into the IP address field
Note: If you wish to use a different address, be sure **not** to use the same address that is to be used with the QuadView XL. These addresses must be different.
- Type the subnet mask 255.255.255.0 into the subnet mask entry field
- Click on the OK button to accept the new address and exit the properties page
- Click on the OK button to exit the Local Area Connection Properties menu
- Click on the Close button in the Local Area Connection Status menu

3. QuadView XL network settings

To make setup easier, the QuadView XL is supplied with a factory set static IP address (192.168.1.200). If you are using the QuadView XL in a direct connection there is no need for you to change this address. However if you are going to use unit directly on a LAN then you will need to reset this address to be compatible with your network. (see next section).

If you wish to change the QuadView XL IP address before accessing it via the Ethernet port, you can connect to the QuadView XL via the serial port. Use the command 'IPADDR' to check and set the QuadView XL IP address. Then continue with step 4.

4. Connecting to QuadView XL

Control of the QuadView XL can be achieved using the Web Control Panel (WCP) or by command line using a Telnet connection, These two methods are described in the following section:

Web Control Panel

To control via the WCP use the following procedure:

- Open your web browser (MS Internet Explorer is recommended)
- In the web browser address line type the IP address of the QuadView XL (if you are using the default address type 192.168.1.200) and press GO.
- If the connection is correct the browser will show the QuadView XL login page.
- Type 'RGB' (upper case) and press enter and the main page should load.

Command Line Control

To control via a command line interface you will need to use a telnet window. Use the following procedure:

- Click on the START button of your PC and select 'RUN'
- Type 'command' in the RUN entry box
- Type 'telnet ' 192.168.1.200 8000' in the command window
- If the connection is working the QuadView XL will respond with a start up message.
- Commands may now be entered from the telnet window in the same way as you would enter them for a serial control session.

If you have difficulty in connecting see the trouble shooting guide later in this document.

NETWORK CONNECTION

If you are going to connect the QuadView XL to a local area network (LAN) then use the following procedure:

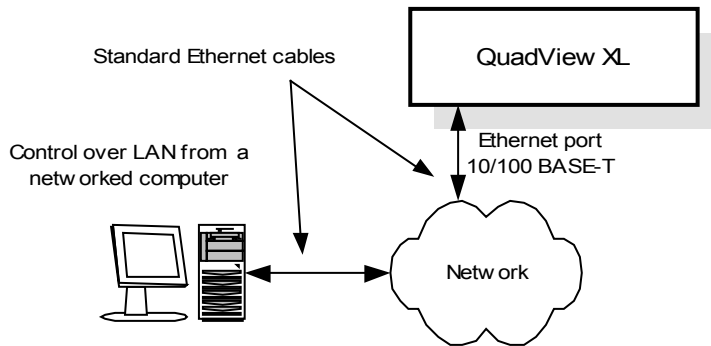

Figure 4. Ethernet network connection

There are several steps required to connect directly from your PC to the QuadView XL.

1. QuadView XL network settings

IMPORTANT: To make setup easier, the QuadView XL is supplied with a factory set static IP address. This default IP address is 192.168.1.200. Because you are intending to use the unit directly on a LAN you will probably need to reset this address to be compatible with your network. A LAN is typically configured by a network manager who can provide you with a valid IP address.

To avoid network address conflict issues the easiest way to configure your QuadView XL for the network is to change the QuadView XL IP address before you connect to the LAN. This is easily accomplished using the serial port.

- From the serial terminal, type the command 'IPADDR' to check and set the QuadView XL IP address.
- Type the command 'IPADDR <ipaddress>', where the term <ipaddress> represents the new IP address.
- Press enter
- To confirm the new IP address type the command 'IPADDR' and the QuadView XL will respond with the current IP address.

2. Connect Ethernet Cable

- Connect a standard Ethernet cable between the QuadView XL and the network

3. Set up the network settings of your PC (Windows XP)

- If your PC is already operating on the network then there should be no changes required with the set up of your PC.

4. Verify connection

It is now time to verify that the connection is working.

Web Control Panel

To control via the WCP use the following procedure:

- Open your web browser (MS Internet Explorer is recommended)
- Type the IP address of the QuadView XL (use the address you set in Step 1) and click on GO
- If the connection is correct the browser will show the QuadView XL login page
- Type 'RGB' (upper case) and press enter and the main page should load

Command Line Control

To control via a command line interface you will need to use a telnet window. Use the following procedure:

- Click on the START button of your PC and select 'RUN'
- Type 'command' in the RUN entry box
- Type 'telnet <ipaddress> 8000' in the command window (<ipaddress> is the address you set up in Step 1).
- If the connection is working the QuadView XL will respond with a start up message.
- Commands may now be entered from the telnet window in the same way as you would enter them for a serial control session.

If you have difficulty in connecting see the trouble shooting guide later in this document.

4. TROUBLE SHOOTING

Connection problems may consist of electrical or network configuration issues. Ethernet ports are generally adaptable between 10 and 100 Mbps, and interconnection problems are usually due to using the wrong type of cable. When the QuadView XL is connected to a network (switch or hub) a standard Ethernet cable should be used. However if the PC is connected directly to the QuadView XL without the use of a hub or switch, an Ethernet cross over cable must be used.

Symptom	Problem
<p>There does not seem to be a connection from the PC to QV XL when connected directly. QV XL does not respond to a 'ping'.</p>	<p>Electrical connection incorrect</p> <p>1) The cable between the QV XL and PC may be of the incorrect type. Check that cable is a crossover cable and not a standard Ethernet cable. Replace the cable and use the IP command 'ping' to check the connection is working.</p> <p>You may be pinging the wrong IP address. Check the QV XL IP address through the serial port using the IPADDR command. Change the address using the same command if necessary.</p>
<p>The PC responds with an error message when I try to use the 'ping' or 'ipconfig' or 'telnet' commands.</p>	<p>Path Setting</p> <p>If Windows responds to the 'ping', 'ipconfig' or telnet command with a message indicating that this is not a valid command it is probably due to the path setting not including the path to the IP commands. Use the Windows explorer to search the hard drive for the location of ping.exe.</p>
<p>I see a reply to the 'ping' command, but I cannot connect using the 'telnet' command or browser.</p>	<p>Duplicate IP address</p> <p>Check to see that you are pinging the correct address. Use the 'ipconfig' command to check the IP address of your PC. If the address of the PC and the QuadView XL are the same then the response that you are seeing is from the PC, not the QuadView XL.</p>
<p>When I use the telnet command I connect but the QV XL message is incorrect (127.0.0.1 login:)</p>	<p>Incorrect Port number</p> <p>If you see a prompt with the message "127.0.0.1 login:", then you have logged in as a telnet session. This happens when you omit the port number 8000 from the end of the IP address.</p> <p>Close the telnet session and start again by typing 'telnet <ipaddress> 8000' (where <ipaddress> is the IP address of the QuadView XL you are trying to connect to).</p>